

Airport Visual Aids Research

ICAO Workshop on Air
Navigation Visual Aids
New Technologies

May 7-11, 2012

ICAO South American
Regional Office

Lima, Peru

Presented by Alvin Logan

FAA AAS-100



Federal Aviation
Administration



Outline

- Engineering Brief Updates
- Final Approach Runway Occupancy Signal (FAROS)
- Enhanced Flight Vision System
- Night Vision Goggles
- Conspicuity of LEDs in Fog



Outline

- Runway Status Lights (RWSL)
- RWSL THL/ALSF-II Assessment
- LED Evolution
- LED Research
- Delta Airlines Incident on Taxiway



Engineering Brief Updates



Federal Aviation
Administration

Draft Engineering Briefs

- EB-84 for ALCMS Security Draft
 - Design and use of virtual private network (VPN) systems to enable secure off-site remote maintenance and monitoring of airport lighting control monitoring systems (ALCMS).

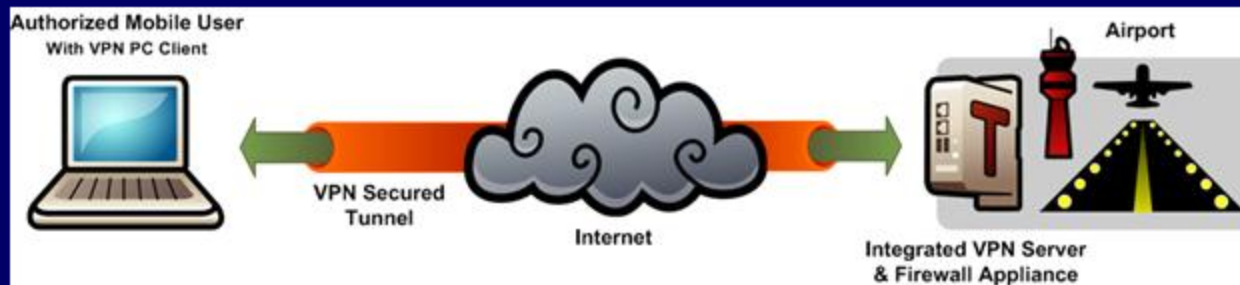

Secure access to critical systems for remote support personnel



Federal Aviation
Administration

Draft Engineering Briefs

- EB for Night Vision Imagery System
 - Provides information and guidance for the use of night vision systems on board both rotary and fixed wing aircraft. In addition, a prototype LED obstruction light fixture with built-in NVIS compatibility is proposed.



Draft Engineering Briefs

- EB-89 – Guidance for Taxiway Naming Convention
 - This Engineering Brief provides clarification for taxiway naming convention standards contained in FAA Advisory Circular (AC) 150/5340-18F, Standards for Airport Sign Systems.
- EB-XX – FAROS
 - Design guidance for implementation of a direct warning system (based on LOOPs sensor) to airborne flight crews of runway occupancy status.



FAROS



Federal Aviation
Administration

FAROS

- Developed by ANC-G5, Office of Advanced Concepts & Technology Development
- EB for FAROS/eFAROS
 - Design guidance for implementation of a direct warning system (based on LOOPs sensor) to airborne flight crews of runway occupancy status.
- FAROS Engineering Brief has been circulated to FAA Regions for comment to make a determination of feasibility, practicality of usage.



FAROS

FAROS Annunciation
(User Interaction)

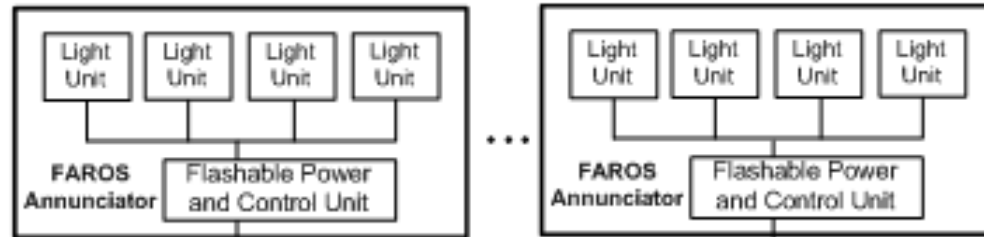

FAROS Safety Logic and Tracking
(Command Logic)



FAROS Localized Sensor
(Surveillance Input)

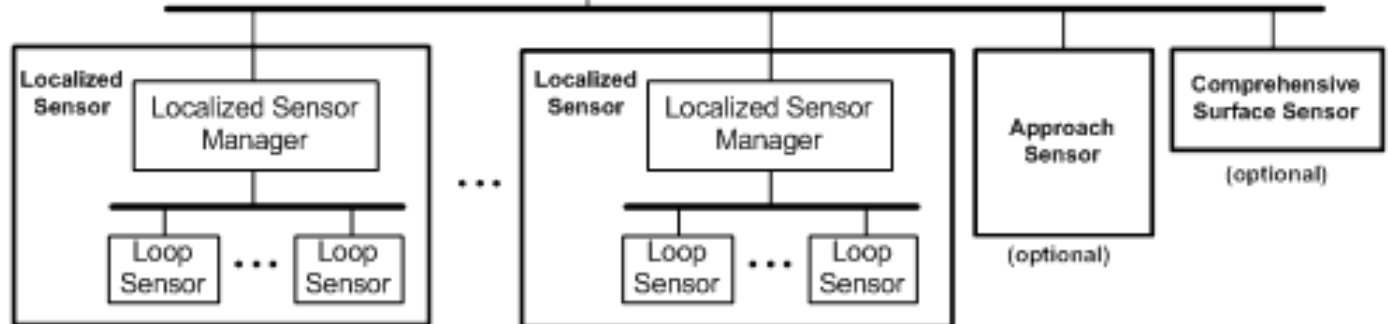

FAROS Operational Concept

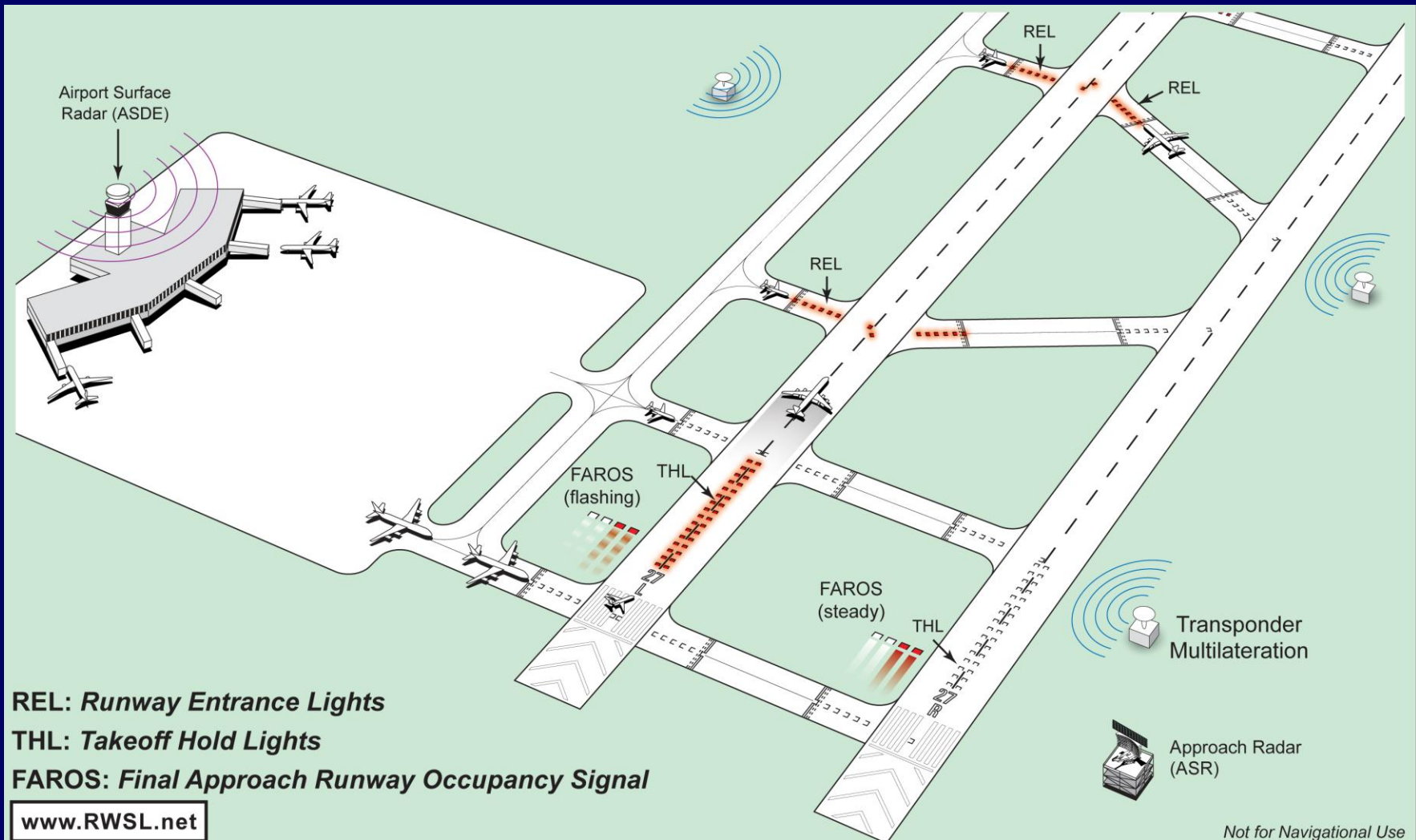

Federal Aviation
Administration

EFVS



Federal Aviation
Administration

Enhanced Flight Vision Systems (EFVS)

- 14 CFR 1.1 defines EFVS as –

“Enhanced flight vision system (EFVS) means an electronic means to provide a display of the forward external scene topography (the natural or manmade features of a place or region especially in a way to show their relative positions and elevation) through the use of imaging sensors, such as a forward looking infrared, millimeter wave radiometry, millimeter wave radar, low light level image intensifying. “



Performance-Based Cockpit Technology in Low Visibility Operations

Benefits

- Enhances low visibility flight and ground operations.
- Increases access, efficiency and throughput at many airports when low visibility is a factor.
- Reduces infrastructure necessary to support low visibility operations.



Low Visibility Landing



Performance-Based Cockpit Technology in Low Visibility Operations

- Provides flight guidance on a HUD
- Provides a real time display of the outside world in low visibility conditions through the use of imaging sensors (forward looking infrared, millimeter wave, low-light level intensifying, etc.)



HUD + Sensor Imagery = EFVS



Federal Aviation
Administration

Operational Concept for EFVS

- Permitted on straight-in landing instrument approach procedures other than Category II or Category III (*i.e., nonprecision, Category I precision, and APV*).
- Provides another means of operating in the visual segment – EFVS in lieu of natural vision.
- EFVS enables descent below DA or MDA to 100 feet above TDZE provided certain requirements are met --
 - Enhanced flight visibility equal to/greater than that specified in the IAP.
 - Required visual references must be distinctly visible/identifiable.
 - All other requirements of § 91.175 (l) must be met.
- Requires natural vision to be used to identify required visual references for descent below 100 feet above TDZE.

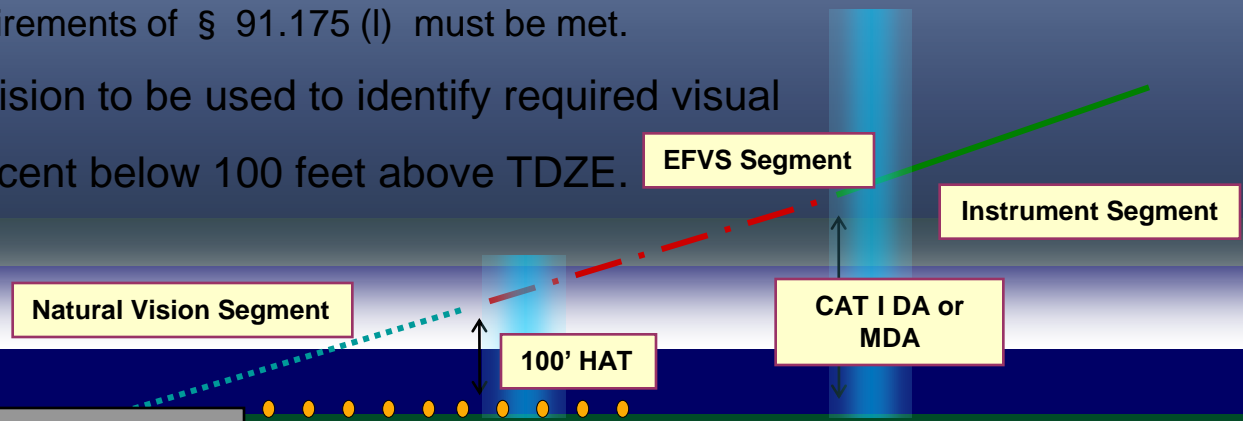

Illustration Courtesy of Mitre CAASD



Federal Aviation
Administration

Ongoing Actions for EFVS

- Attend and participate in SAE G-20 committee meetings for EFVS.
- Participate in EFVS MALSR/IR program reviews within the Navigation Services Group.
- Participate in EFVS NPRM (Newly Published Rule Making) Document Preparation.
 - EFVS NPRM to be signed May 16, 2012



Night Vision Goggles



Federal Aviation
Administration

MIL-STD-3009

METRIC

MIL-STD-3009
2 February 2001

SUPERSEDING
MIL-L-85762A

DEPARTMENT OF DEFENSE
INTERFACE STANDARD



- LIGHTING, AIRCRAFT, NIGHT VISION IMAGING SYSTEM (NVIS) COMPATIBLE
- NVGs derived from military requirements.
- Provides interface requirements and testing methodology to ensure compatible and standardized aircraft interior lighting for NVIS compatibility.



Federal Aviation
Administration

Night Vision Goggles

- Claim: LEDs cannot be seen with Night Vision Goggles!
- Visible light detected is independent of the lighting technology.
 - It is based on the spectrum the NVG technology uses.
- NVGs have either Type A or B filters which changes the spectrum sensed.



Night Vision Goggles

- Commonly used Gen 3 NVGs sensitivity range is from approx. 450nm to 920nm.
- Commonly produced LEDs are from 460nm for Blue to 645nm for Red.
- NVG Gen3 without filters will respond to Green, Yellow, and Red LEDs.



Night Vision Goggles

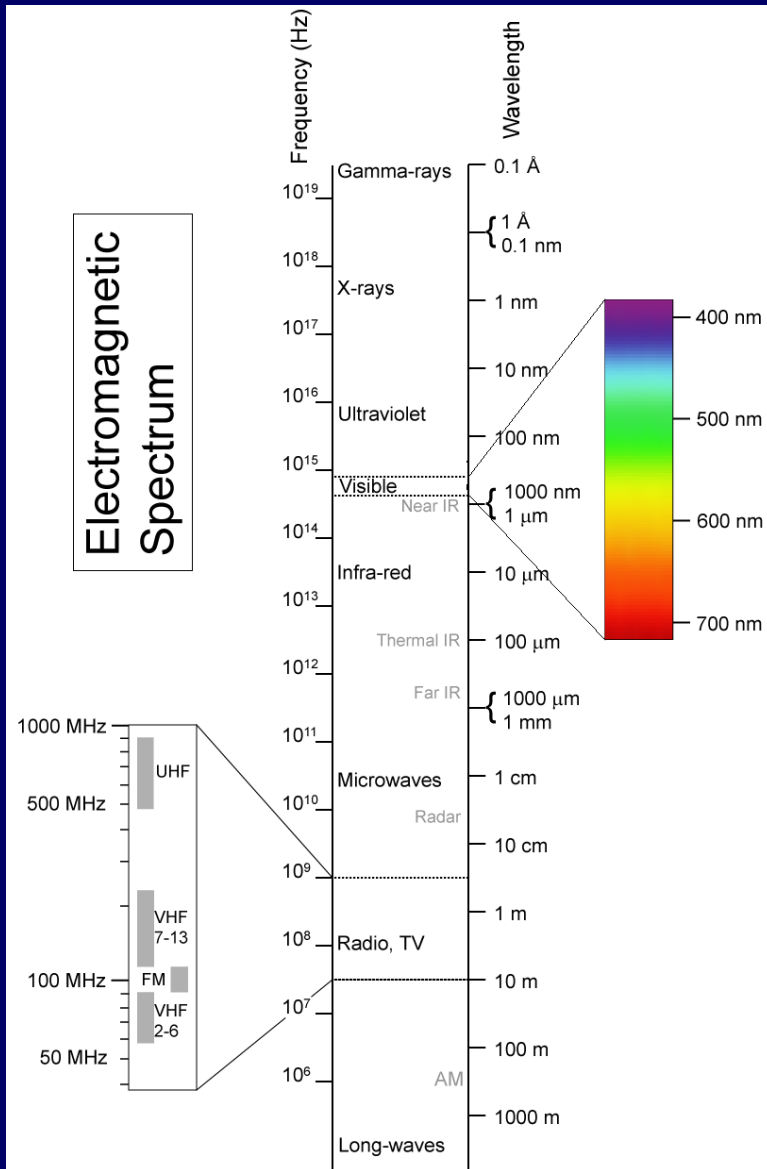

- **NVGs' spectral response in the range of approximately 600 to 900 nanometers in wavelength.**



Federal Aviation
Administration

Visible Spectrum

VISIBLE SPECTRUM OF LIGHT		
Vacuum wavelength (nm)	Frequency (10^{12} Hz)	Brain color response
730-622	410-482	RED
622-597	482-503	ORANGE
597-577	503-520	YELLOW
577-492	520-610	GREEN
492-455	610-659	BLUE
455-370	659-810	VIOLET



Incandescent Light Output Spectrum

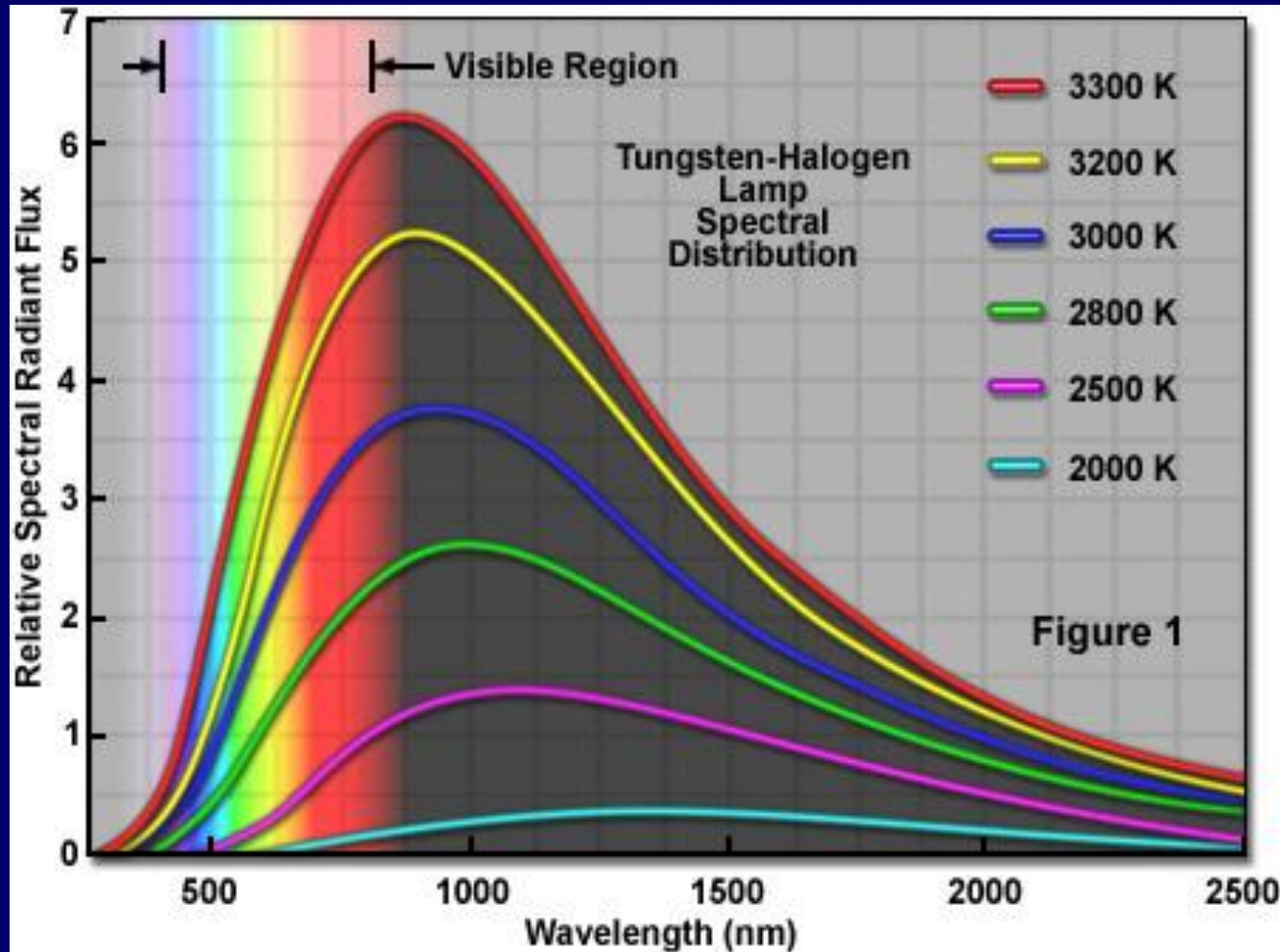

Typical Red LED Spectrum

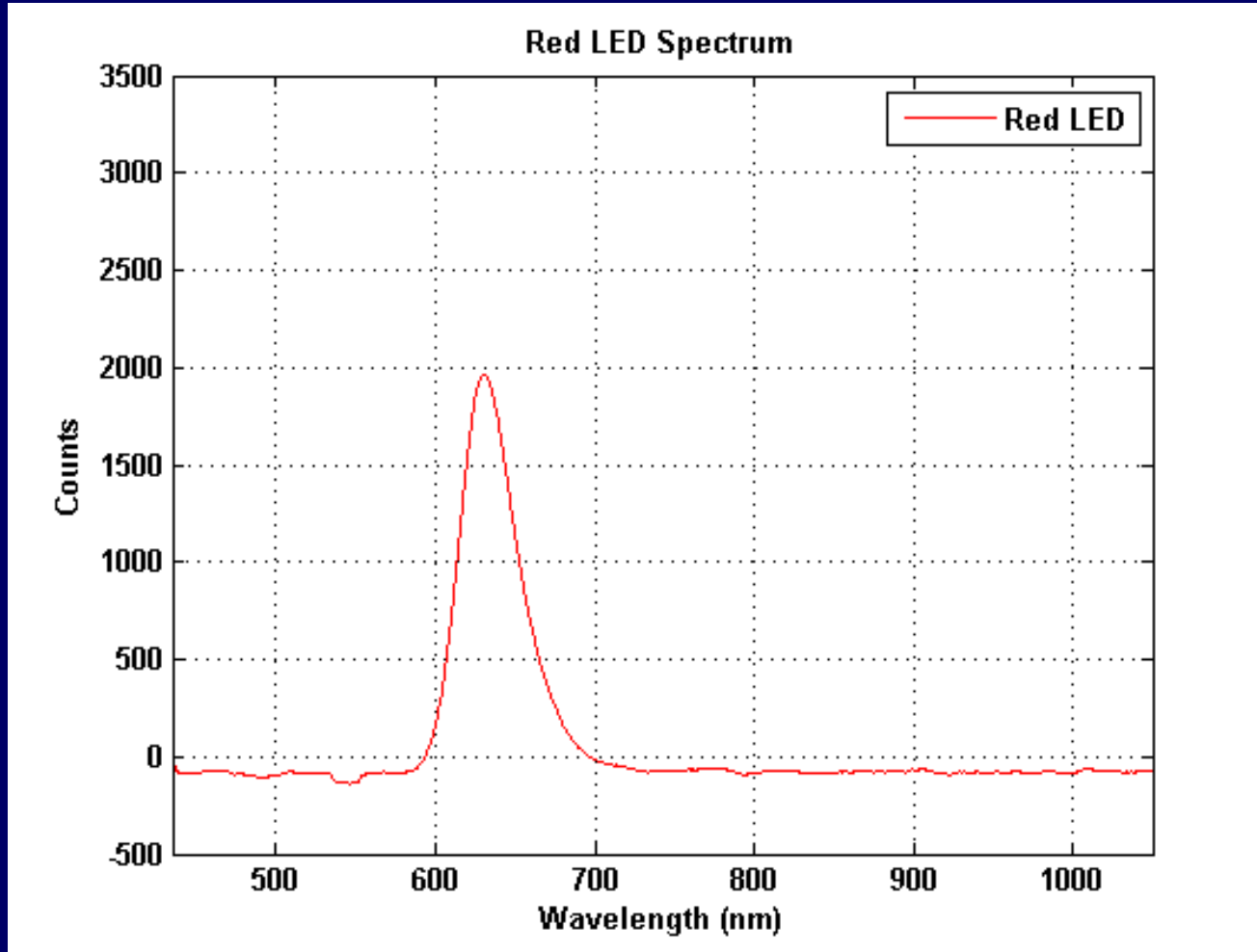

Night Vision Goggles

- Class A filters respond at wavelengths longer than 625nm and Class B at 665nm.
- NVGs can detect red LEDs using Class A filters.
- NVGs cannot detect any LEDs using Class B filters. Some incandescent lights may be seen.



Night Vision Goggles

**L-810 LED Red Obstruction
Light from 60 ft using NVGs
with Class A filter**



Federal Aviation
Administration

Conspicuity of Incandescent and LEDs in Fog



Federal Aviation
Administration

Are LEDs Visible in Fog?

LED & INCANDESCENT LIGHTS
IN LOW VISIBILITY STUDY



00:01



Federal Aviation
Administration

Issues with Implementing LED Technology

Claim: LEDs can not be seen as well as Incandescent lights in low visibility?

True or False?

FALSE!

Any source with the same Candela value can be seen the same in a given visibility.

Except...



Federal Aviation
Administration

Perceived Brightness

- There is a quantifiable “Brightness/Luminance” (B/L) conversion factor with LEDs.
 - Conversion to Incandescent:
 - Blue B/L = 1.4
 - White B/L = 1.6
 - Green B/L = 1.4
 - However, light scattered by Fog can desaturate LED signal colors reducing or eliminating the brightness advantage.



Issues with Implementing LED Technology



Issues with Implementing LED Technology



Incandescent & LED Lights at same intensity
observed from 100 feet.

LED light still has GREEN appearance.



Federal Aviation
Administration

Runway Status Lights



Federal Aviation
Administration

RWSL



- Purpose
 - Reduce frequency and severity of runway incursions
 - Prevent runway accidents
- RWSL increases situational awareness
 - RELs provide a *direct indication* to pilots when it is unsafe to cross or enter a runway
 - THLs provide a *direct indication* to pilots when it is unsafe to depart from a runway



RWSL System Architecture

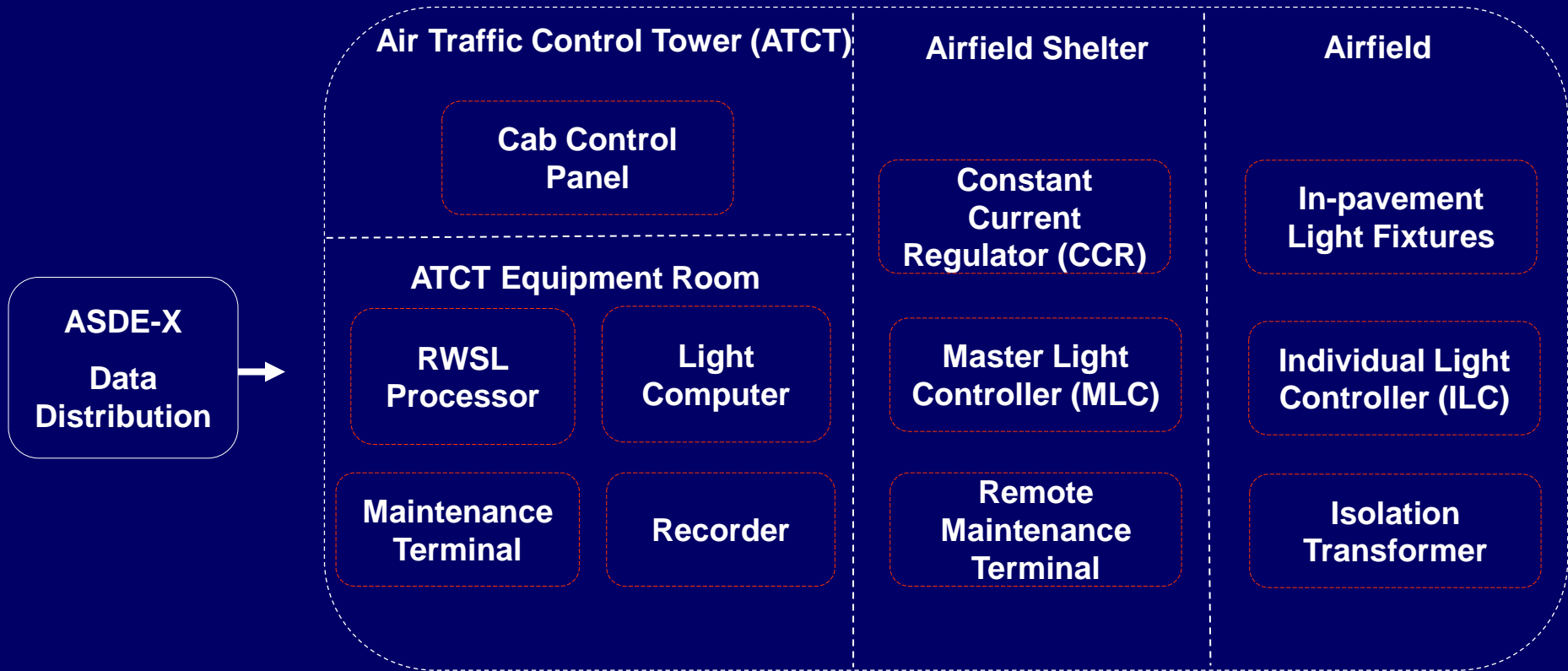

LEGEND



Existing NAS Hardware



New RWSL Hardware



Federal Aviation
Administration

RWSL RELs and THLs

Runway Status Lights integrates airport lighting equipment with approach and surface surveillance systems to provide a visual signal to pilots indicating that it is unsafe to enter/cross or begin takeoff on runway



Runway Entrance Lights (REL) provide signal to aircraft crossing runway from intersecting taxiway



Takeoff Hold Lights (THL) provide signal to aircraft in position for takeoff



Federal Aviation
Administration

RELs at San Diego



Federal Aviation
Administration



THLs at Step 5 at LAX

General Overview of Equipment

RWSL Processor
Lighting Computer
(LC) Processor

Field
Lighting
Shelter

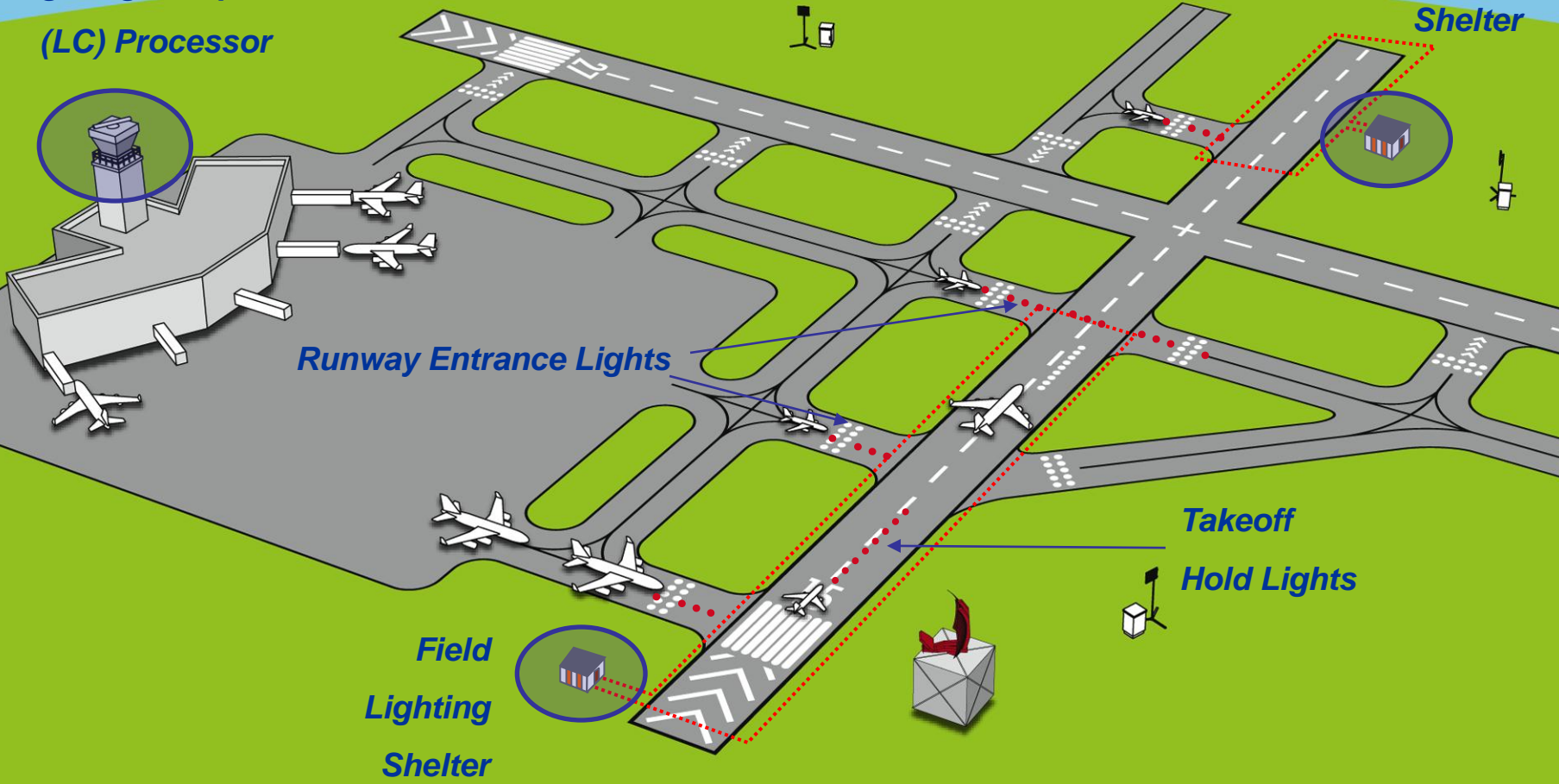

(Up to 4 Circuits)

ASDE-X

ASDE-X System using Surface Movement Radar (SMR) & Multi-lateration accurately pinpoint aircraft location

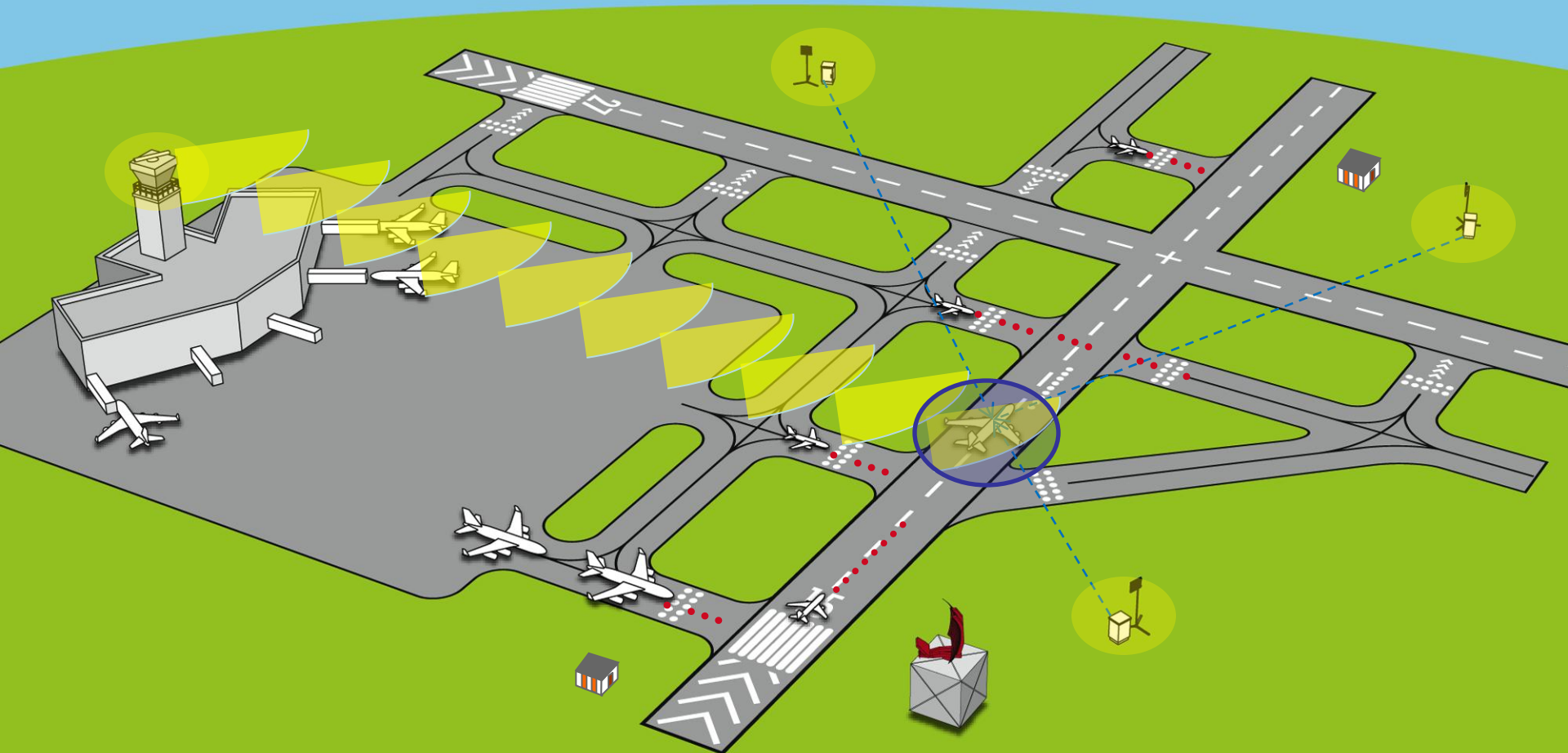

Field Lighting System (FLS)

Runway Entry Lights (RELs) & Take-Off Hold Lights (THLs) are automatically controlled

Lights turn On when aircraft are occupying the runways

Lights are Off otherwise

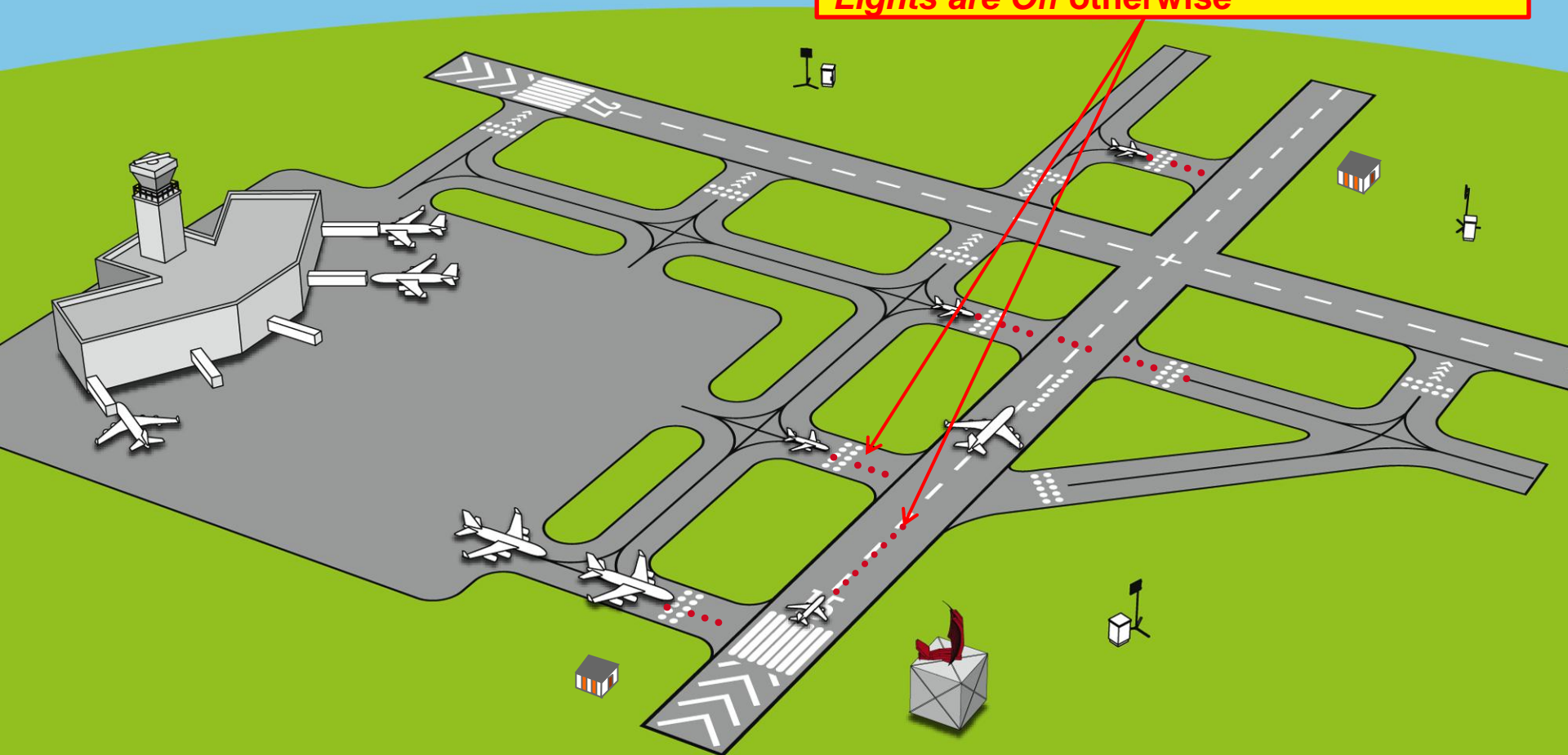

Concurrent with RWSL the ASDE-X System notifies Air Traffic Controllers if an aircraft or vehicle enters an active runway with an audible Safety Alert

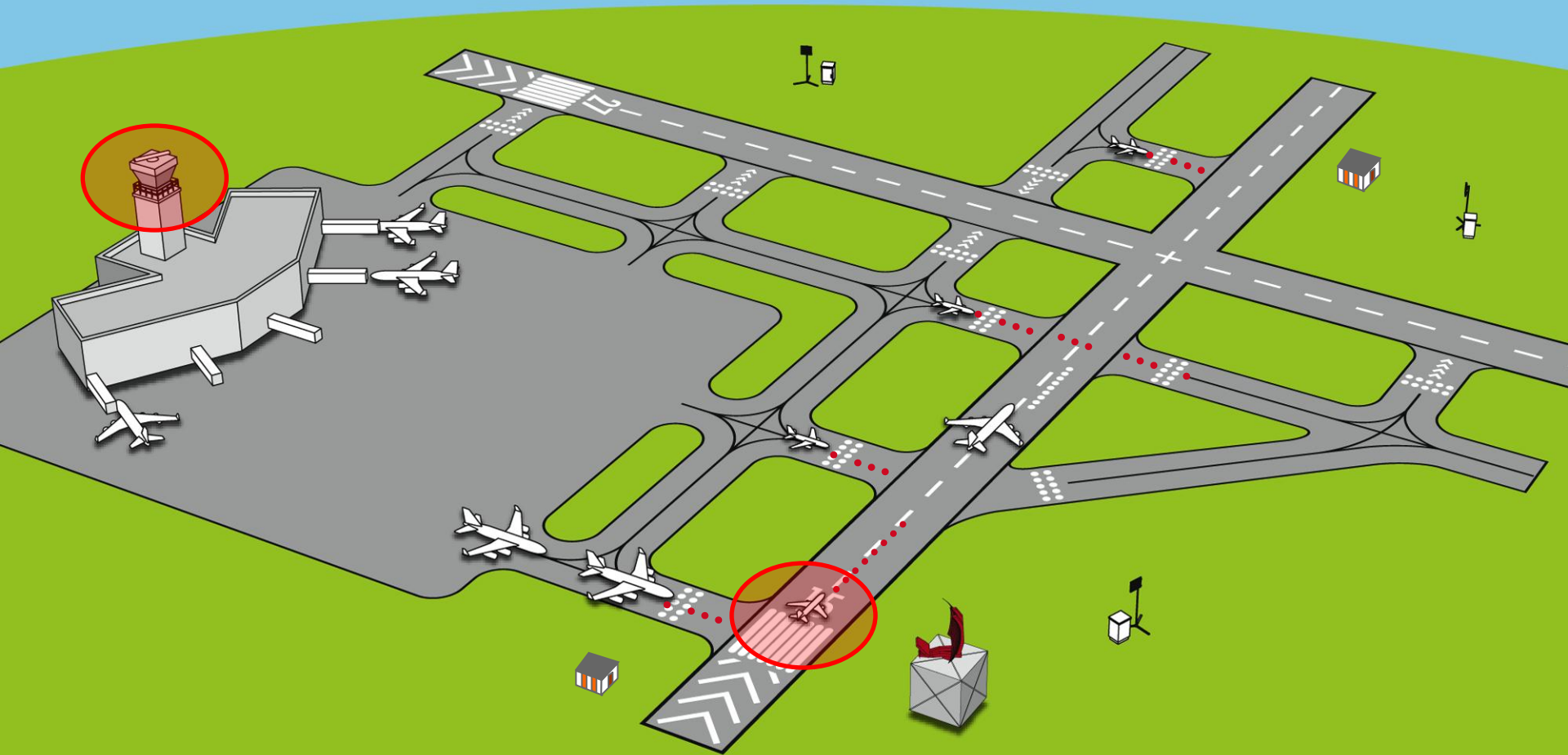

RWSL

FAA RWSL In-pavement LED

- FAA Certified
- 12", Style III (<1/4" above pavement)
- Instant turn-on time, even in lower intensity steps.
- Fixtures are electronically monitored to detect individual fixture failure locations
- Available with optional heater



Runway Entrance Light
REL L-852S

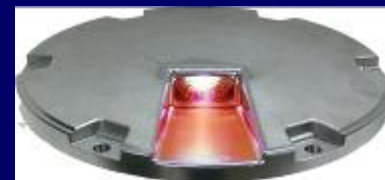

Takeoff Hold Light
THL L-850T

REL L-852S

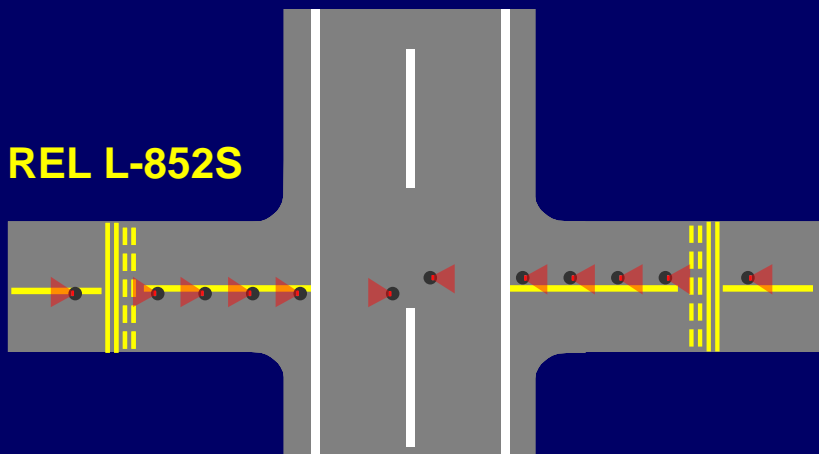

THL L-850T

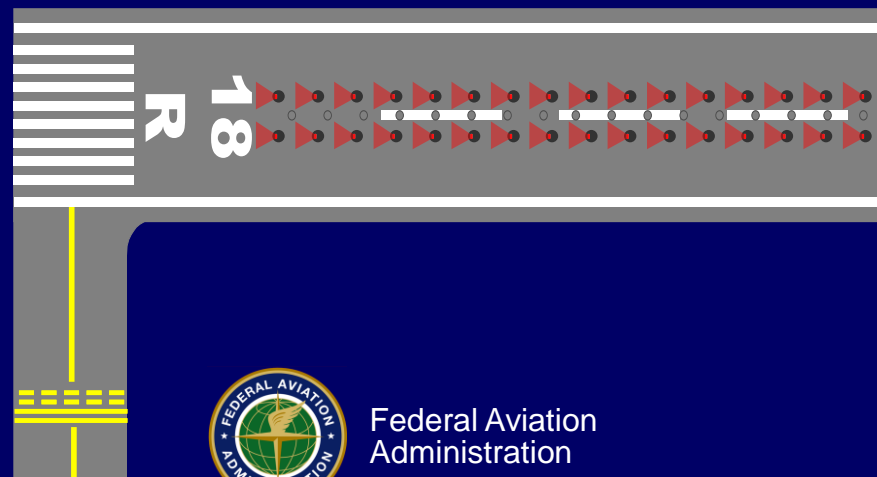

Federal Aviation
Administration

RWSL SAFO



U.S. Department
of Transportation

**Federal Aviation
Administration**

SAFO

Safety Alert for Operators

SAFO 11009

DATE: 10/26/11

Flight Standards Service
Washington, DC

http://www.faa.gov/other_visit/aviation_industry/airline_operators/airline_safety/safo

A SAFO contains important safety information and may include recommended action. SAFO content should be especially valuable to air carriers in meeting their statutory duty to provide service with the highest possible degree of safety in the public interest. Besides the specific action recommended in a SAFO, an alternative action may be as effective in addressing the safety issue named in the SAFO.

Subject: Runway Status Lights (RWSL)

Purpose: This SAFO serves to ensure that aircraft operators, pilots and airport personnel are aware of the installation, meaning, and use of RWSLs.



Federal Aviation
Administration

RWSL Production System Airport List

ID	Region	Airport
MCO	ASO	Orlando International Airport
IAH	ASW	George Bush Intercontinental Airport
PHX	ASW	Phoenix Sky Harbor International Airport
SEA	ANM	Seattle-Tacoma International Airport
IAD	AEA	Washington Dulles International Airport
CLT	ASO	Charlotte Douglas International Airport
FLL	ASO	Ft. Lauderdale/Hollywood Airport
MSP	AGL	Minneapolis-St. Paul International Airport
LAS	AWP	Las Vegas McCarran International Airport
ORD	AGL	Chicago O'Hare International Airport
LGA	AEA	LaGuardia Airport
JFK	AEA	John F. Kennedy International Airport
DTW	AGL	Detroit Metro Wayne County Airport
EWR	AEA	Newark International Airport
PHL	AEA	Philadelphia International Airport
DFW	ASW	Dallas/Ft. Worth International Airport
LAX	AWP	Los Angeles International Airport
SAN	AWP	San Diego International Airport
BWI	AEA	Baltimore-Washington International Airport
BOS	ANE	Boston Logan International Airport
ATL	ASO	Hartsfield-Jackson Atlanta International Airport
DEN	ANM	Denver International Airport
SFO	AWP	San Francisco International Airport
PSF		Oklahoma City - NAS Engineering Program Support Facility (PSF)
ILS		Oklahoma City - FAA Logistics Center/Depot
ACA		Oklahoma City - FAA Academy



RWSL Program Office

Claude Jones	Program Manager	202-385-8407
Barbara Kratz	Project Lead	202-385-8645
Mike Weiler	Implementation Lead	202-385-8767
Bashar Halabi	Engineering lead	202-385-8695
Cynthia Schauland	Integrated Logistics Support Lead	202-603-6796
Jim Hayes Dave Reynolds	Contracts	202-385-8644 202-385-8658



Federal Aviation
Administration

RWSL THLs and ALSF-II Evaluation



Federal Aviation
Administration

BOS Logan

- Synopsis:

The incident occurred on 6/24/2011 at 1217UTC. DAL561 advised he was seeing red lights while in position on runway 4R. The crew refused to takeoff, did not roll and an arrival to 4R had to go around.



BOS Logan

Discussion:

- There was a recent pilot RWSL survey at BOS.
- There are no RWSL THLs on BOS 4R
- Pilot's comments regarding the acquisition red lights on that runway was puzzling.
- Weather at BOS that day was low IFR
- Aircraft arriving to 4R on a CAT II ILS approach.



Runway Safety Assessment Response to Takeoff Hold Lights

Completed Testing in MITRE CAASD Simulator:

- Test for Pilot Confusion between THLs and ALSF-2:
 - **It exists!**
- MITRE Outcome Briefing to FAA



ALSF-2



THLs



Runway Safety Assessment Response to Takeoff Hold Lights

- Runway Safety Assessment (RSA) for Pilot Response to Takeoff Hold Lights underway.
- Mitre, ANC-G5, Office of Advanced Concepts & Technology Development, AAS-100, Airport Engineering Division and Flight Standards.



Runway Safety Assessment Response to Takeoff Hold Lights

Multiple suggestions have been provided to help mitigate confusion

1. Increase awareness and training
2. Alter illumination pattern of THLs
3. Extinguish red barrettes of ALSF-II during takeoff operations.

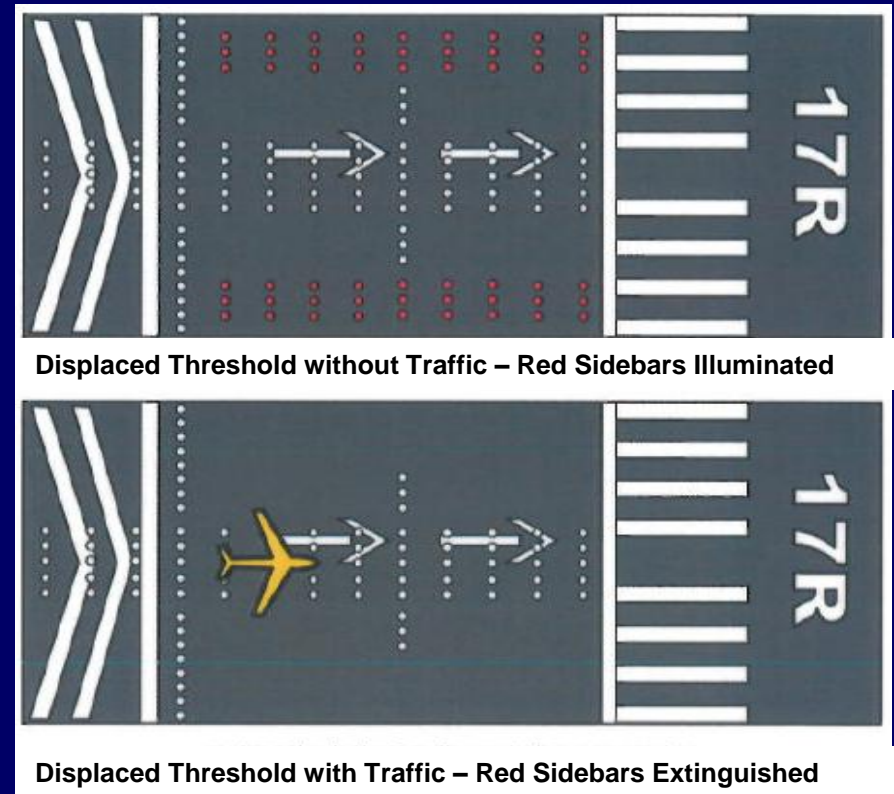

Light Emitting Diodes



Federal Aviation
Administration

LED Composition

- Aluminum gallium indium phosphide (AlGaInP)
 - Produces red, orange and yellow LEDs
- Indium gallium nitride (InGaN)
 - Produces red, green and blue LEDs
- Mixture of red, green and blue LEDs produces white LEDs OR blue LED + phosphor material.



LED Evolution

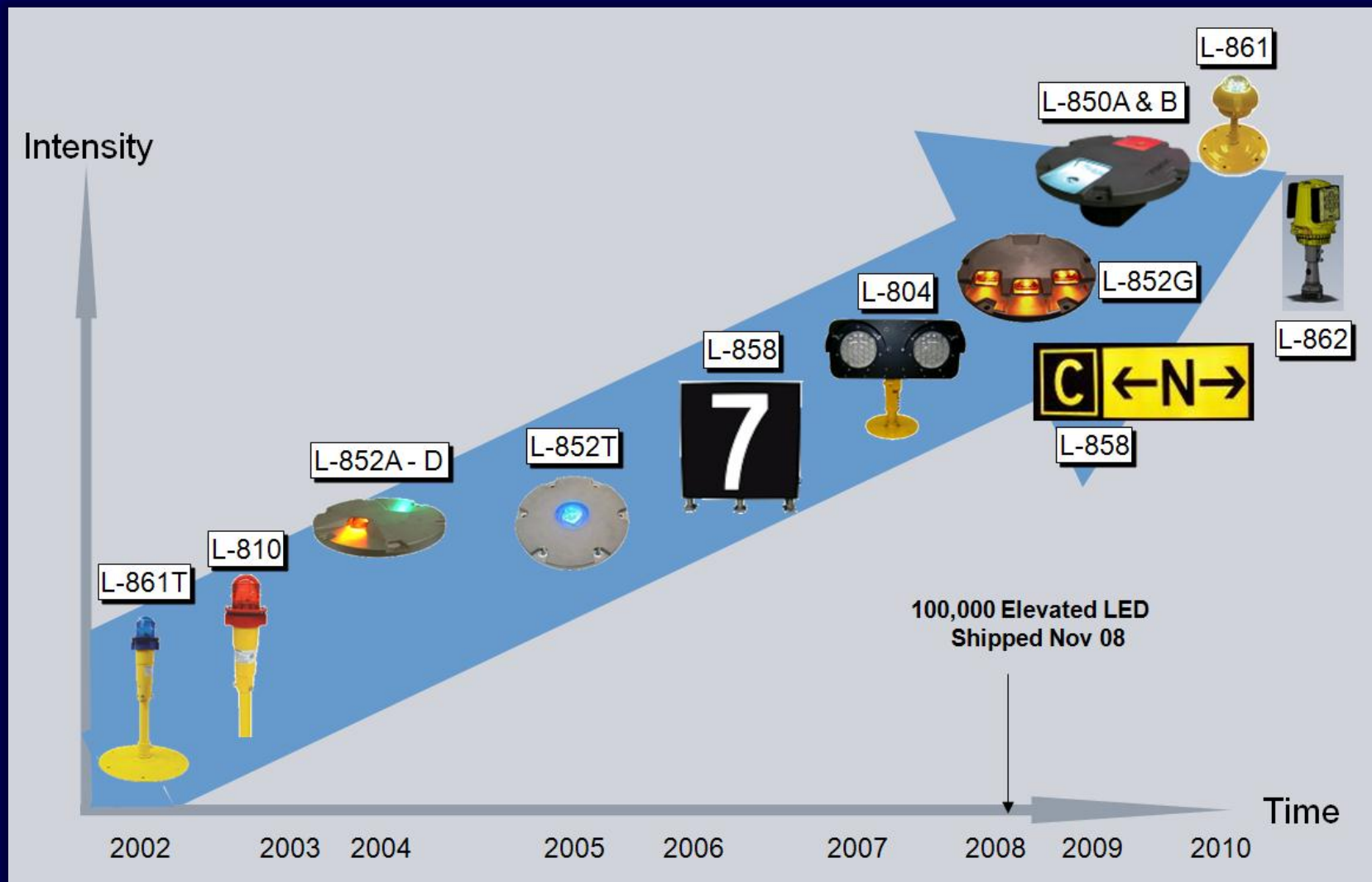

Federal Aviation
Administration

LED Deployment

- FAA Certified Lighting Manufacturers have sold and installed at least 1 million LED Lighting Applications



Fixture Icing Problems?

Heaters are Available!

Per FAA Eng. Brief 67C, “Any fixture, with the exception of obstruction lights... may have an optional arctic kit or/and appropriate addressing of potential icing conditions to no less extent than present fixtures. An arctic kit may be an optional feature.” The arctic kit must be self-activating.



Federal Aviation
Administration

LED Research



Federal Aviation
Administration

Elevated Runway Guard Lights Evaluation



Federal Aviation
Administration

Elevated Runway Guard Light

- Most major airports implement Runway Guard Lights.
 - As a supplemental device used in conjunction with hold position markings and signs.
 - Due to operations under low visibility conditions
 - Hard-wired Runway Guard Lights
 - Require Infrastructure
 - What about General Aviation (GA) airports?



Elevated Runway Guard Light

- General Aviation Airports
 - “Hot Spots”
 - Pilots and drivers crossing the active runway unauthorized creating a runway incursion.
 - Problem with implementing Runway Guard lights is cost.
 - New Technology



Elevated Runway Guard Light

- A prototype Solar-powered light emitting diode (LED) runway guard light unit was developed.
 - FAA's L-804 Lamp Housing
 - Solar Panel
- Initial evaluations were implemented at the Tech Center
 - Different climate conditions
- Field Testing
 - Dupage Airport, Chicago Installed May 2008
 - Provo Airport, Provo, UT Installed May 2008



Elevated Runway Guard Light



Federal Aviation
Administration

Dupage Airport RGL



Federal Aviation
Administration

Provo Airport RGL



Federal Aviation
Administration

Elevated Runway Guard Light

- Currently
 - Collecting pilot data (Surveys)
 - Monitoring systems at both airports
- Evaluation continuing



Minimum Intensity for Incandescent Runway Guard Lights (RGL)

- Prior to 1996, the minimum luminous intensity requirement was 600 cd
 - **Increased to 3000 cd** based on results from **1996 study**
- Flash rate was also increased from 30 cycles per minute to 45-50 cycles per minute
 - Study looked at 30, 48 & 60 flashes per minute



Elevated Runway Guard Light Evaluation (ERGL)

- Rensselaer Polytechnic Institute – Lighting Research Center Study
- Laboratory study completed
 - **Scope:**
 - **Min. Intensity for Incandescent Lamps and LEDs**
 - **Recommendations for flash frequency for LED system**
 - **Recommendations for duty cycle for LED system**
 - **Impact of waveform profile shape for LED system**



Experimental Outline

- Phase 1 – Identify minimum luminous intensity for incandescent RGL across all ambient conditions
- Phase 2 – Determine the optimum level for each variable (frequency, duty cycle, waveform, ambient condition)
- Phase 3 – Apply decreasing levels of intensity for each promising combination of variables at each ambient condition



Test Apparatus



Federal Aviation
Administration

Test Apparatus

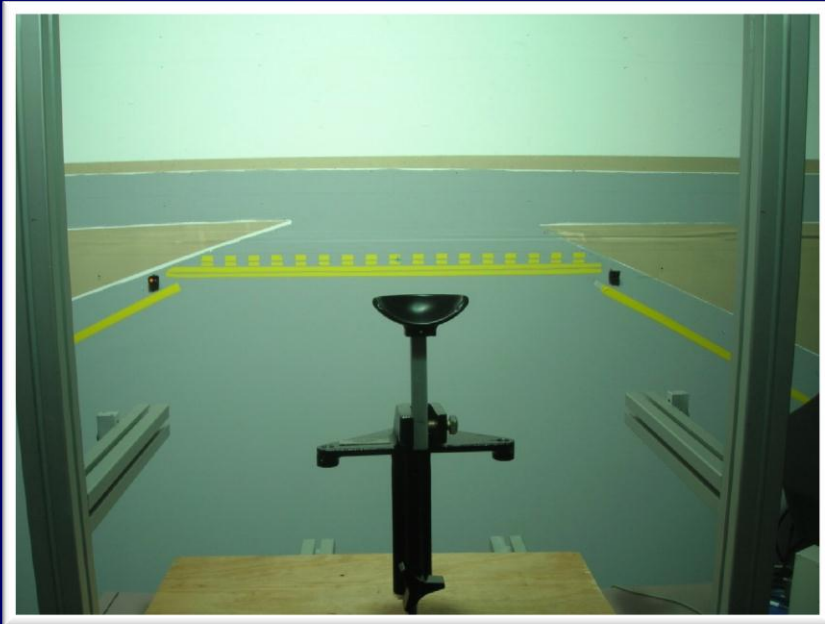

Subject View



Foggy Day Setup



Federal Aviation
Administration

Subject Characterization

- Ten subjects for each trial
- Subject pool was fairly consistent across all trials
- Age range: 22 – 62
- Visual acuity (binocular)
Avg: 20/25 Minimum: 20/50
- All subjects demonstrated normal color vision

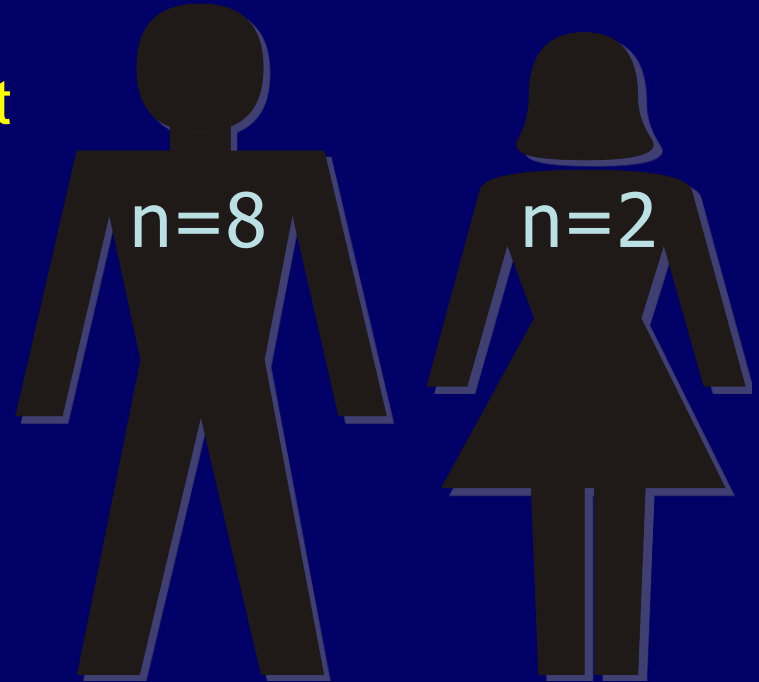

Technology-Neutral Specification

- Results indicate that square waveform is more conspicuous than triangle or incandescent waveform
- Intensity required will be based on combination of other factors (e.g., duty cycle and frequency combination)
- LEDs can be “tuned” to offer these effective combinations (and energy savings) but other technologies may evolve to offer the same effectiveness



Findings

- It is not recommended that the current incandescent-based ERGL specification be changed.
- LED ERGL intensities could be reduced.



Recommendations

LED ERGL Step	Current Standard	Recommended Value
Step 3 (100%)	3000 cd	451-1128 cd
Step 1 (10%)	300 cd	68-113 cd

- These values can be obtained by a combination of selecting a square wave signal, flash rate, and on-time percentage.
- The best flash rates & on-time percentages were: 1.25 Hz @ 70% or 2.50 Hz @ 30%



Moving Forward

- Field study are being conducted to validate results before final recommendations are made.



LEDs and Color Vision Deficiency



Federal Aviation
Administration

LED Applications Issues

Does the “narrow spectral band” of LEDs impact pilots with certain types of color deficient vision?

CIVIL AEROSPACE MEDICAL INSTITUTE (CAMI) and Airport Safety Technology R&D (AJP-6311) completed March 2010 an evaluation on this issue sponsored by the Lighting Systems Office, AJW-46 and Office of Airport Safety and Standards, AAS-1.



Federal Aviation
Administration

LEDs and Color Deficiency Issue

- Approximately 8% of males and 0.5% of females in the population have congenital red-green color-deficient vision.
- They have reduced ability to discriminate redness-greenness throughout the full gamut of colors.
- The problem includes the red, orange, yellow, and yellow-green parts of the visible spectrum.
- Red and green are not uniformly replaced by grey. For some people with color-vision deficiency, colors like beige and yellow replace red and green.



LED Applications Issues

- The three main varieties of color-vision deficiency
 1. Protan - cannot distinguish reds and greens; reds appear dark and less bright than other colors.
 2. Deutan - like protans, cannot distinguish reds and greens. though, there is no brightness deficiency.
 3. Tritan - blues and greens are confused (less common).
- Majority of color deficient are Deutans.
- Preliminary results show LEDs may actually help Deutans.



LED Color Boundaries



Federal Aviation
Administration

LED Color Boundaries

- Aviation White LED Chromaticity Boundaries
 - Yellow boundary: $x = 0.440$
 - Blue boundary: $x = 0.320$
 - Green boundary: $y = 0.150 + 0.643x$
 - Purple boundary: $y = 0.050 + 0.757x$
- Boundary Intersection Points for Aviation White:
 - $x = 0.320, y = 0.356$
 - $x = 0.440, y = 0.433$
 - $x = 0.440, y = 0.383$
 - $x = 0.320, y = 0.292$



LED Color Boundaries

- Green (ICAO Modified)
- Blue (ICAO)
- Yellow (CIE S 0004/E2001)
- Restricted Red (CIE S 0004/E-2001 restricted region)



RCL Evaluation



Federal Aviation
Administration

Runway Centerline Light Evaluation

- ICAO initiative proposed to evaluate and change current standard.
 - Red means stop!
- Evaluate changing alternating red/white runway centerline lights to alternating yellow/white.
- Also includes evaluating changes to last 1000 feet of red runway centerline to yellow.



Runway Centerline Lights Evaluation

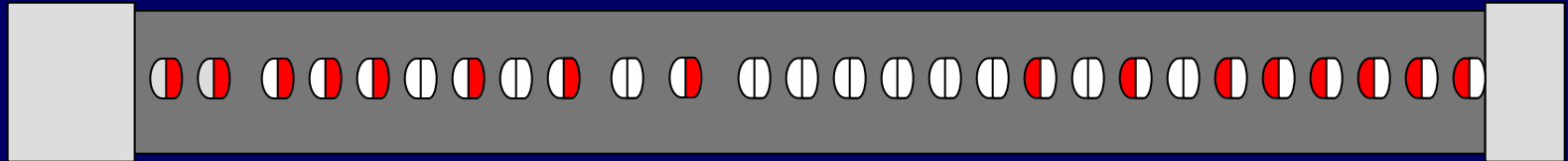

Present

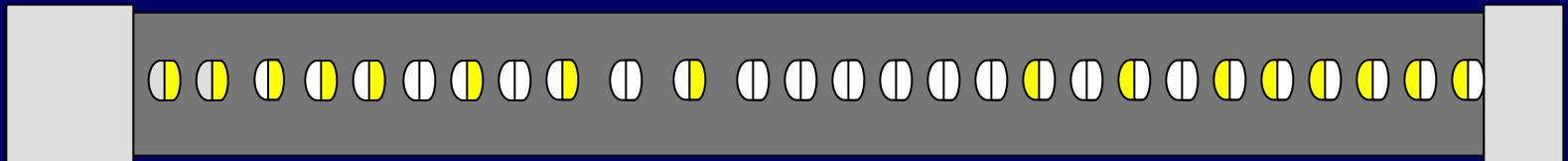

Future?



Federal Aviation
Administration

Delta Airlines Taxiway M Landing at ATL



Federal Aviation
Administration

Delta Airlines Taxiway M Landing - ATL

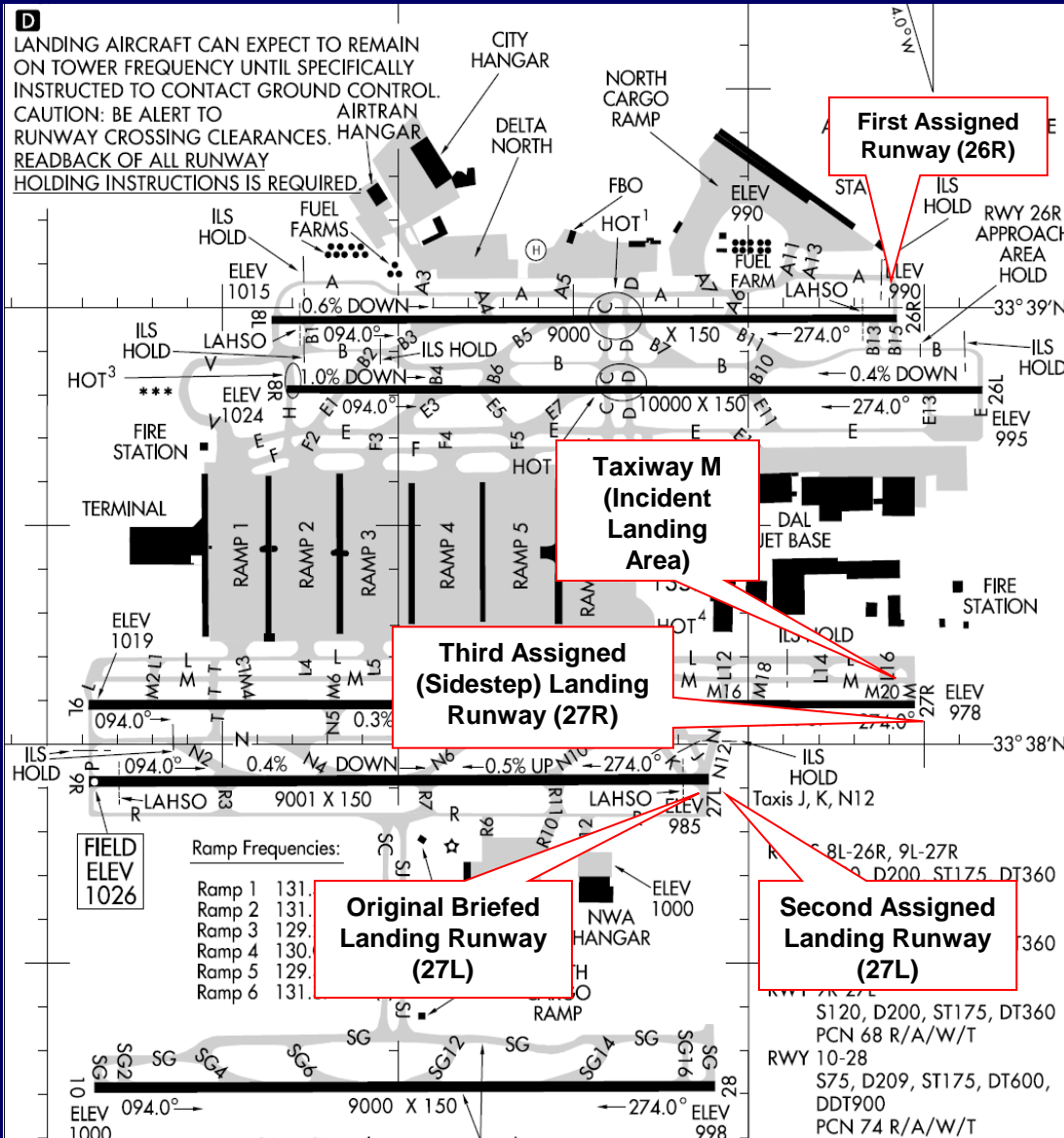

On Monday, October 19, 2009, at 6:05 a.m. EDT, a Boeing B767 operating as Delta Air Lines flight 60 (DL 60) from Rio de Janeiro, Brazil, to Atlanta, Georgia, landed on taxiway M at (ATL) after being cleared to land on runway 27R. No injuries to any of the 182 passengers or 11 crewmembers were reported.



Federal Aviation
Administration

Specifics of that Morning - ATL

- The runway lights for 27R were illuminated.
- Localizer and approach lights for the runway were not turned on.
- Taxiway M was active but was clear of aircraft and ground vehicles at the time the aircraft landed.
- The wind was calm with 10 miles visibility.
- Night VFR conditions prevailed.



Flight Team Investigation



Federal Aviation
Administration

Delta Airlines Taxiway M Landing - ATL

- Runway 27R lights were set on step 1 intensity
- PAPIs for runway 27L and runway 27R were easily discernable however runway 27R was not easily identified.
- Runway 27R edge lights were very dim in comparison to its neighboring taxiway.
- Taxiway M lighting appeared markedly brighter than runway 27R
 - Lights are hardwired on step 3 intensity (100%)



ATL Runway 27L Runway Lights on Step 1



Federal Aviation
Administration

Delta Airlines Taxiway M Landing - ATL

- Numerous signs that marked taxiway M connector taxiway stubs between runway 27R and taxiway L appeared as white edge lighting and mimicked the appearance of a runway.
- LED taxiway centerline lighting lead in lights were bright and could be seen on the taxiway
 - The remaining length of incandescent lights were not as easily identified as were the LED lights



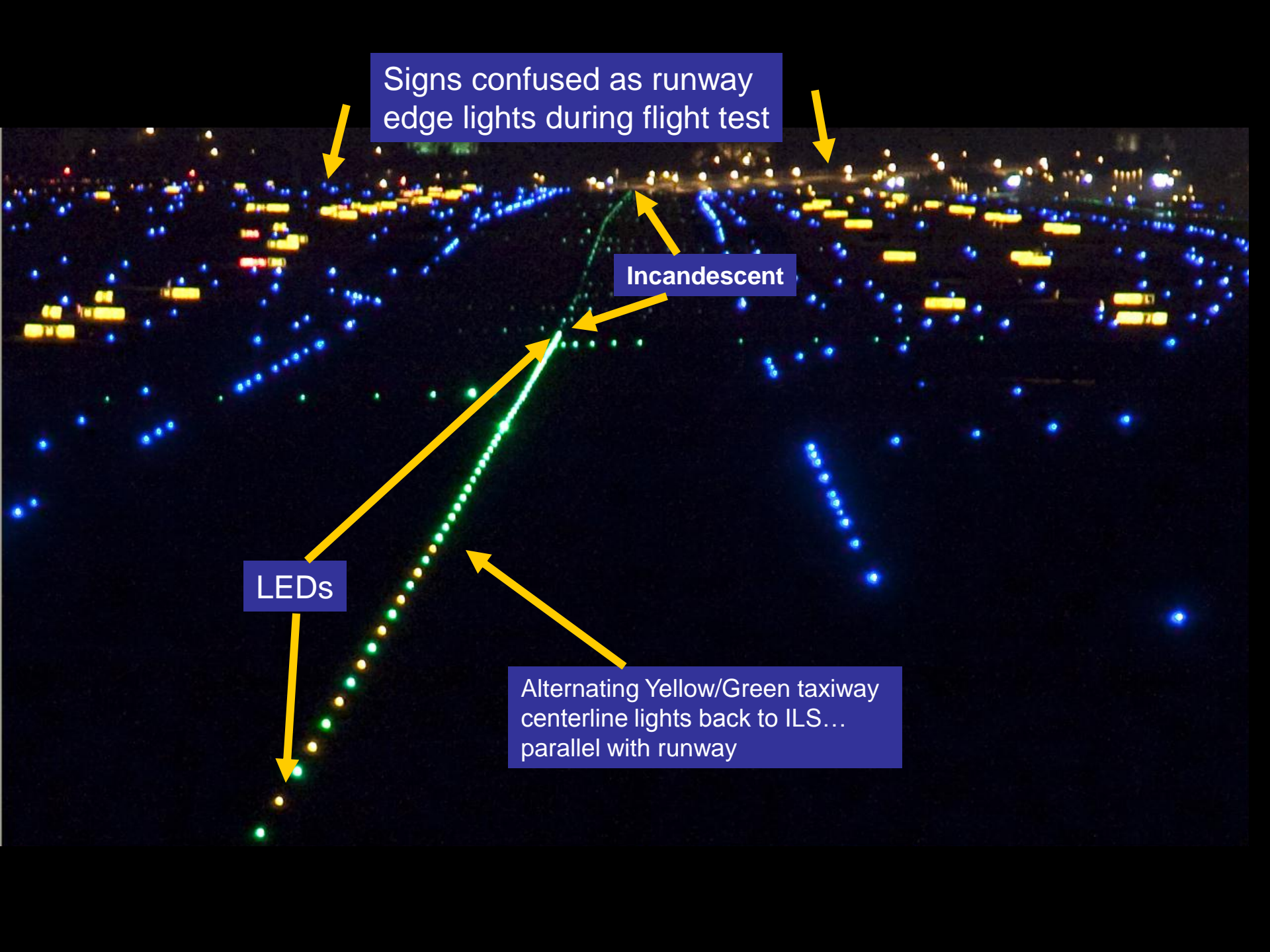

Signs confused as runway edge lights during flight test

Incandescent

LEDs

Alternating Yellow/Green taxiway centerline lights back to ILS... parallel with runway

Delta Airlines Taxiway M Landing - ATL

- The taxiway M lighting was dominant and appeared to be white.
- The illusion that the M taxiway was a runway was further supported with the PAPI position to its left.
 - The PAPI is positioned to the right of runway 27R.
- The wing threshold lights for runway 27R were not easily discernable
 - Perhaps due to the light pollution in the area
 - More dominant lighting on the taxiway



Delta Airlines Taxiway M Landing - ATL

- Runway lights were observed at settings step 1, 2 and step 3
- Step 1 was very dim in comparison to its parallel taxiway, taxiway M.
- Step 2 did not make much difference and was not effective in differentiating the runway from the taxiway.
- Step 3 was very effective and adding the approach lighting to the equation made identification likely.



PAPI on right side of runway,
therefore on left side of parallel taxiway



Federal Aviation
Administration

Measured Chromaticity

- Measured chromaticity for centerline and edge lighting on Taxiway M were within standard.

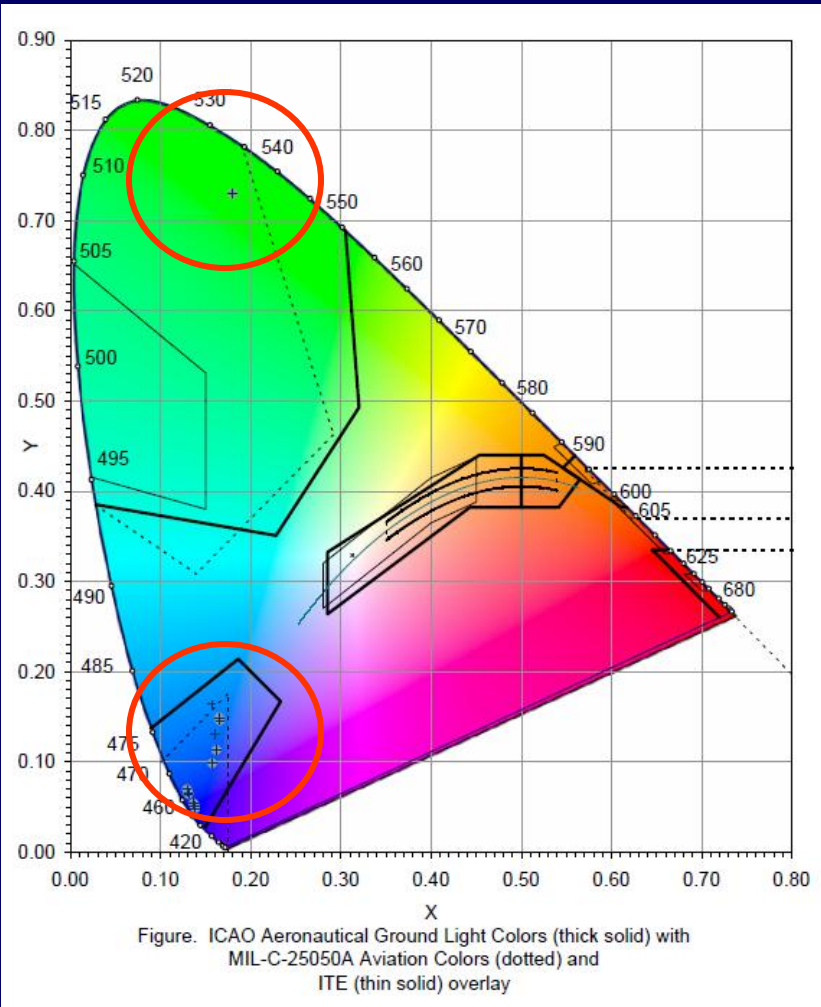

Conclusions of Taxiway M Landing - ATL

- On the date of the incident, the Delta crew misidentified Taxiway M as runway 27R
 - The approach lights and localizer were not activated.
- Consensus of the flight team was that when runway 27R is offered or used for arrival aircraft,
 - Runway edge lights should be set to no lower than step 3
 - Approach lights should be activated to provide adequate visual cues to the flight crews for identifying the runway surface.



Questions?



Federal Aviation
Administration



- NVIS-Class-B-modified cockpit lighting as viewed through Class-A objective lens ANVIS-9 NVGs



- NVIS-Class-B-modified cockpit lighting as viewed through Class-B objective lens ANVIS-9 NVGs. Class-B objective lens filters all light below 665 nanometers.
- Allows the additional use of some red lighting, primarily to allow for three-color multi-function displays



- One of the most common compatibility issues occurs when trying to align a “Class A” or “Class B” objective lens on the night vision device with the lighting configuration of the aircraft.
- Due to the brightness and spectral characteristics of conventional aircraft lighting and the sensitivity of the NVGs’ spectral response in the range of approximately 600 to 900 nanometers in wavelength, the aircraft lighting must be modified for the two to efficiently work together.

